

**1994 Chevrolet Caprice V8-350 5.7L**

**Vehicle: All Technical Service Bulletins  
Transmission Oil Filter Assembly**

Group Ref.: Transmission

Bulletin No.: 377142A

Date: February, 1994

**INFORMATION**

**SUBJECT:  
NEW TRANSMISSION OIL FILTER ASSEMBLY**

**MODELS:  
1994 BUICK ROADMASTER  
1994 CADILLAC FLEETWOOD  
1994 CHEVROLET CAPRICE, CAMARO, CORVETTE  
1994 PONTIAC FIREBIRD  
1994 CHEVROLET AND GMC C/K AND S/T TRUCKS  
1994 CHEVROLET AND GMC M/L AND G VANS  
1994 OLDSMOBILE BRAVADA**

**TRANSMISSION APPLICATIONS:  
1994 HYDRA-MATIC 4L60-E (M30)**

**THIS BULLETIN IS BEING REVISED TO CLARIFY TRANSMISSION USAGE. PLEASE DISCARD BULLETIN 377142.**

**BULLETIN COVERS:**

New product information for 1994 HYDRA-MATIC 4L60-E transmissions. Be certain to familiarize yourself with these updates to properly repair the 1994 HYDRA-MATIC 4L60-E transmission.

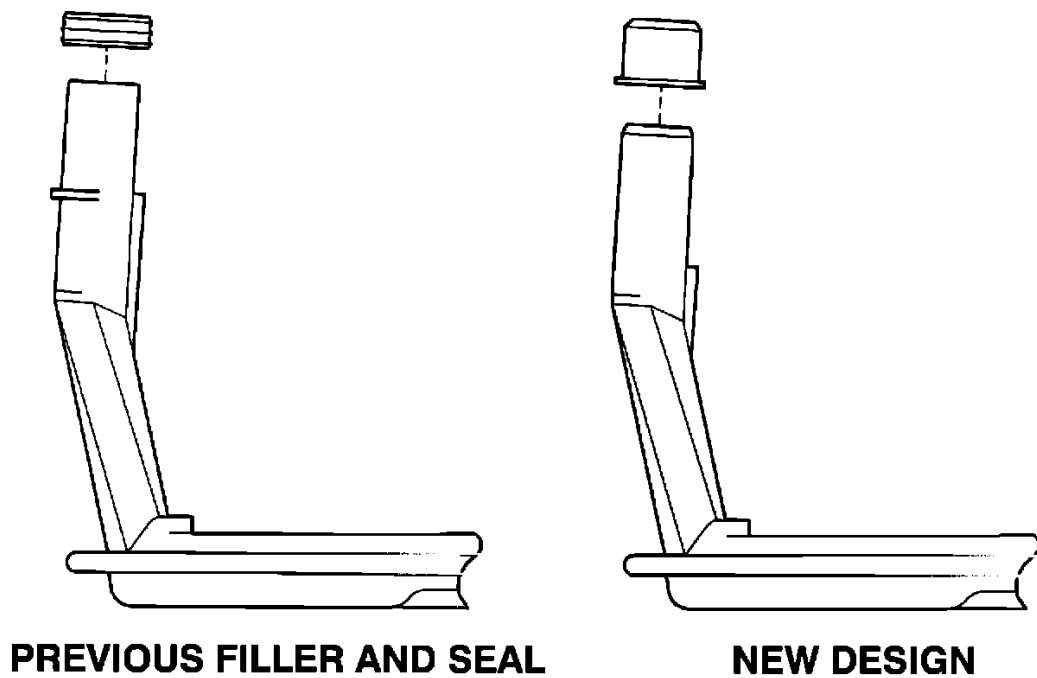

**Figure 1**

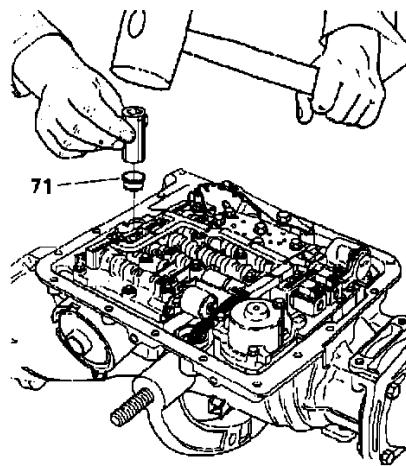

**Figure 2**

**DATE OF PRODUCTION CHANGE:**  
(Figure 1 and 2)

On August 10, 1993 (Julian Date 222), HYDRA-MATIC 4L60-E transmissions were built with a new filter seal (ill. 71) and transmission oil filter assembly (ill. 72).

The previous transmission oil filter assembly and filter seal had an assembly method of installing the seal on the filter neck and then installing the filter in the transmission.

When using the new filter seal and transmission oil filter assembly, the filter seal must be installed in the transmission first and then install the transmission oil filter assembly into the transmission.

**NOTE:**

The new filter seal and transmission oil filter assembly can be used on all HYDRA-MATIC 4L60-E transmissions 1993-1994. The new filter seal and transmission oil filter assembly cannot be used on any HYDRA-MATIC 4L60 transmission.

The new filter seal cannot be used with the old transmission oil filter assembly and the new transmission oil filter assembly cannot be used with the old filter seal.