

Transmission and Drivetrain: All Technical Service Bulletins

3-2 Part Throttle Downshift Flare

File In Section: 7 - Transmission

Bulletin No.: 67-71-47

Date: July, 1996

Subject:
3-2 Part Throttle Downshift Flare (Replace 3-2 Solenoid)

Models:
1996 Buick Roadmaster
1996 Cadillac Fleetwood
1996 Chevrolet Camaro, Caprice, Corvette
1996 Pontiac Firebird
1996 Chevrolet and GMC C/K, M/L, S/T, G Models
1996 Oldsmobile Bravada
with HYDRA-MATIC 4L60-E (RPO M30)

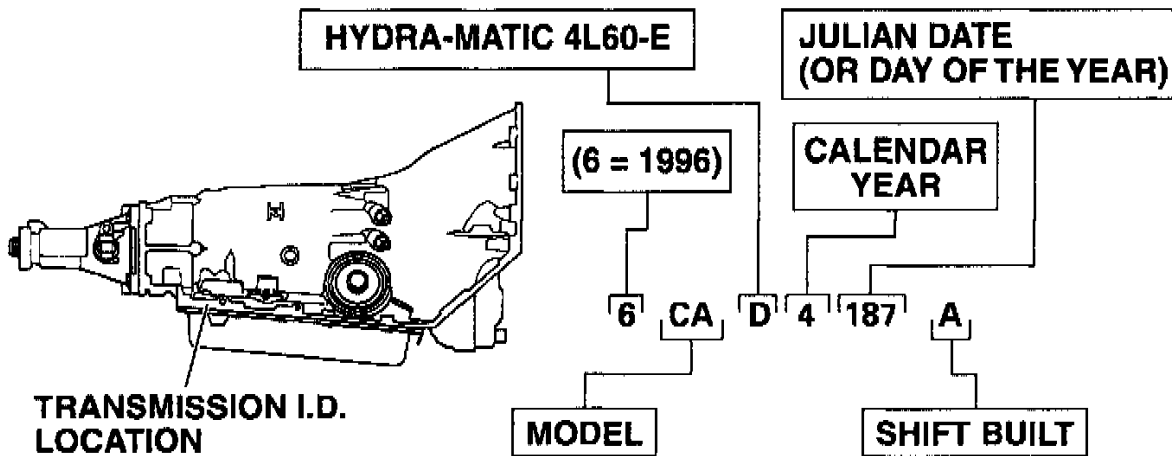

Figure 1 - Hydra-Matic 4L60-E Transmission Identification Information

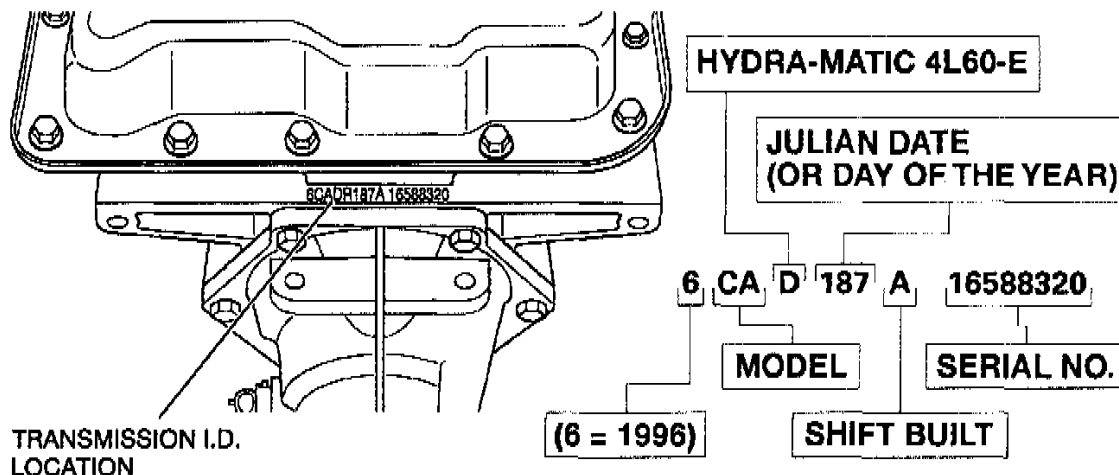

Figure 2 - Hydra-Matic 4L60-E Transmission Identification Information for Two-Piece Case

Condition (Figures 1 and 2)

Some owners of the above models with a HYDRA-MATIC 4L60-E transmission (built before May 24, 1996/Julian Date 6145) may experience an engine speed flare of 1000-2000 RPM, during a part throttle downshift at 19-31 mph. This condition will not set any DTC's (Diagnostic Trouble Codes).

Cause

Exhaust seat on the 3-2 control solenoid backing out.

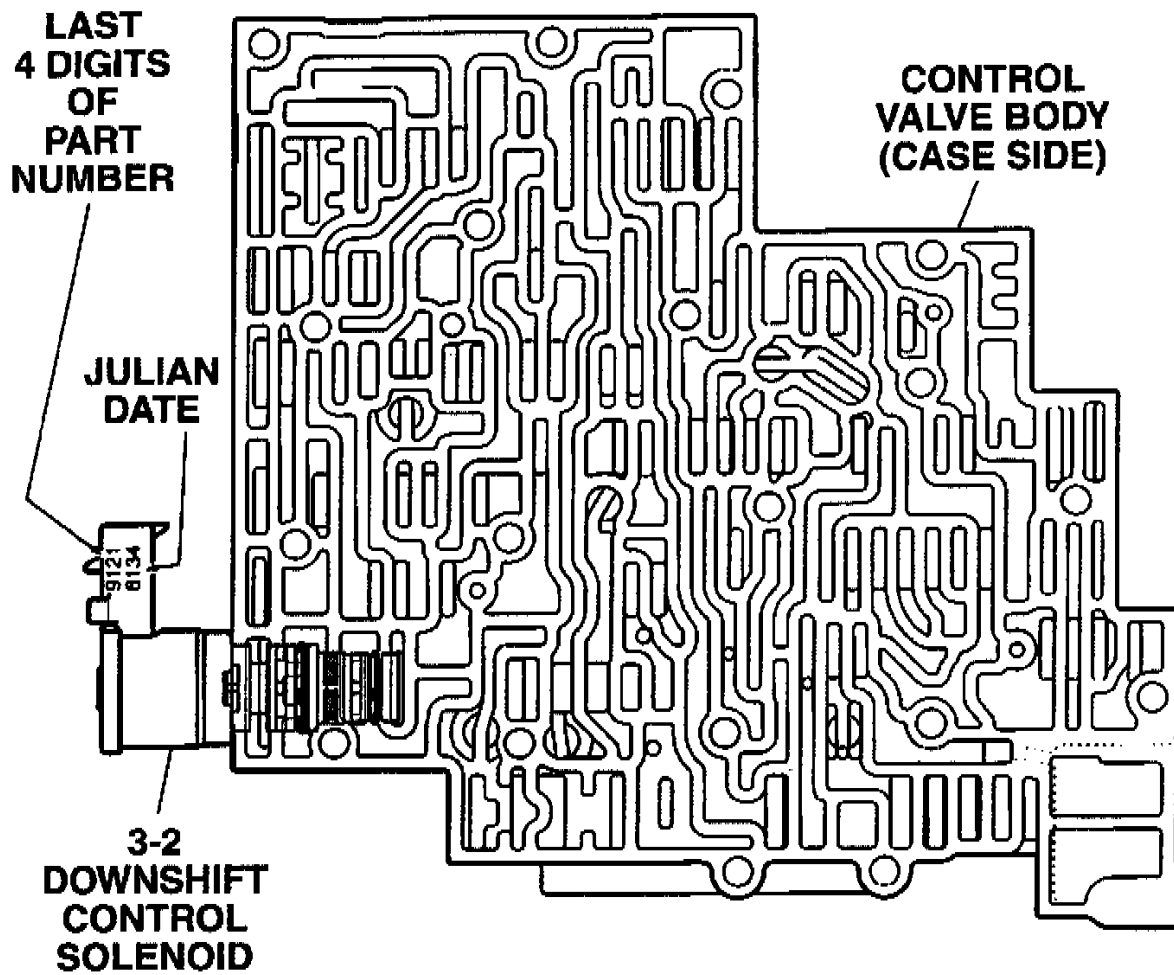

Figure 3 - Location and Identification of the 3-2 Control Solenoid on the Control Valve Body

Correction (Figure 3)

Replace the 3-2 control solenoid. Julian Date on the solenoid will be May 13, 1996 (6134) or later.

Parts Information

New Part Number	Description
24209121	Solenoid, 3-2 Control

Parts are currently available from GMSPO.

Warranty Information

For vehicles repaired under warranty, use:

Labor Operation	Description	Labor Time
K6559	Replace 3-2 Control Solenoid	Use published labor operation time.